

# Disease Dynamics: Implications for Ecosystem Stability

Martina Muraro, Willem Bonnaffé, William Goulding, Sonya Clegg, Tim Coulson

# Disease impact on ecosystem

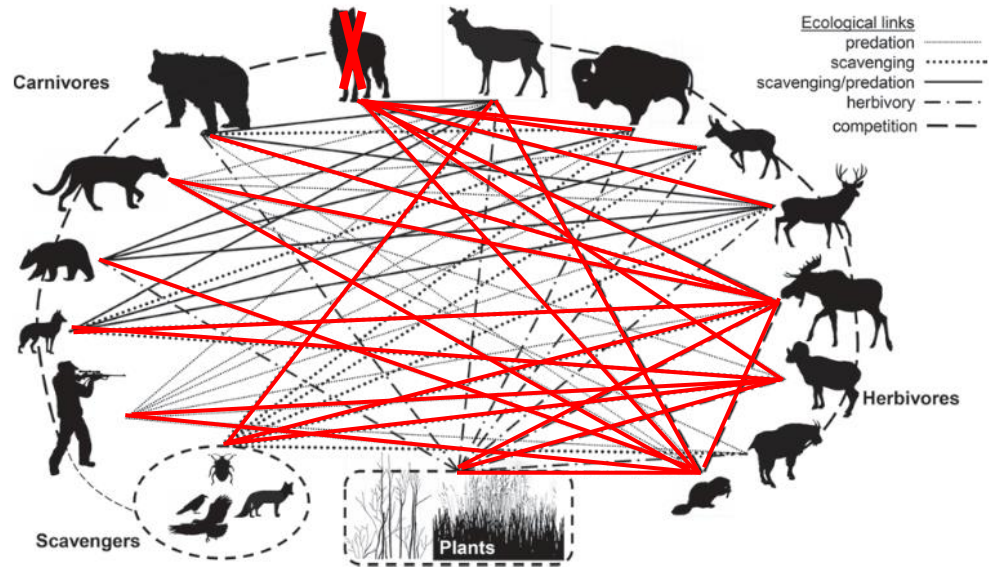

- Ecosystems are intricate networks of interactions
- Altering these components can compromise stability and trigger cascading effects throughout the ecosystem.



# How to predict the cascade effect?

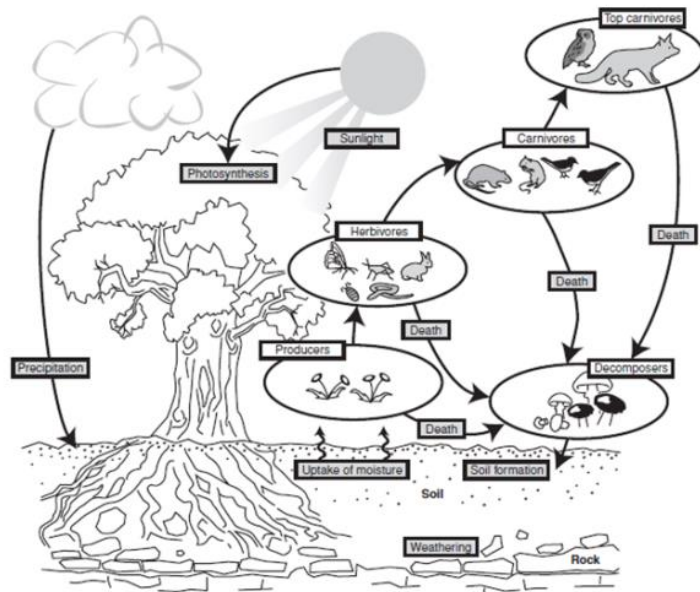

Complex relationships

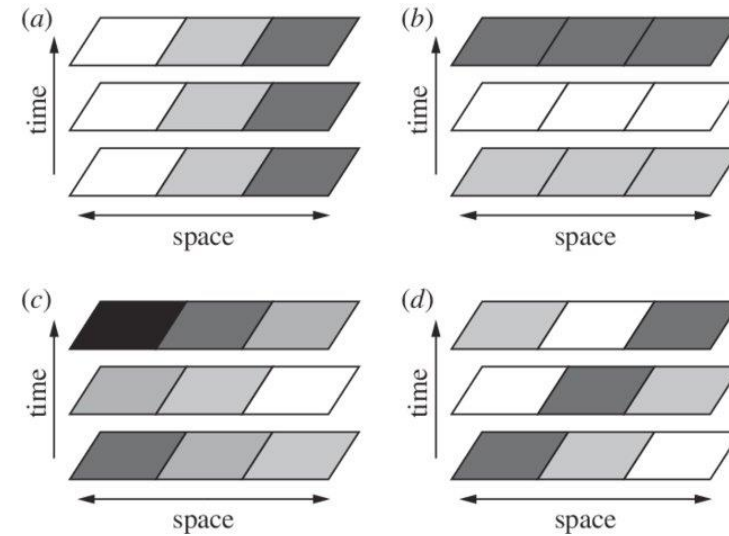

Temporal and Spatial Variability

Bioenergetic Integral Projection Model (IPM)

# BRUCELLOSIS

Brucella bacteria: Gram negative, non-sporing, aerobic bacillus



# Canine Distemper Virus (CDV)

Canine distemper Morbillivirus

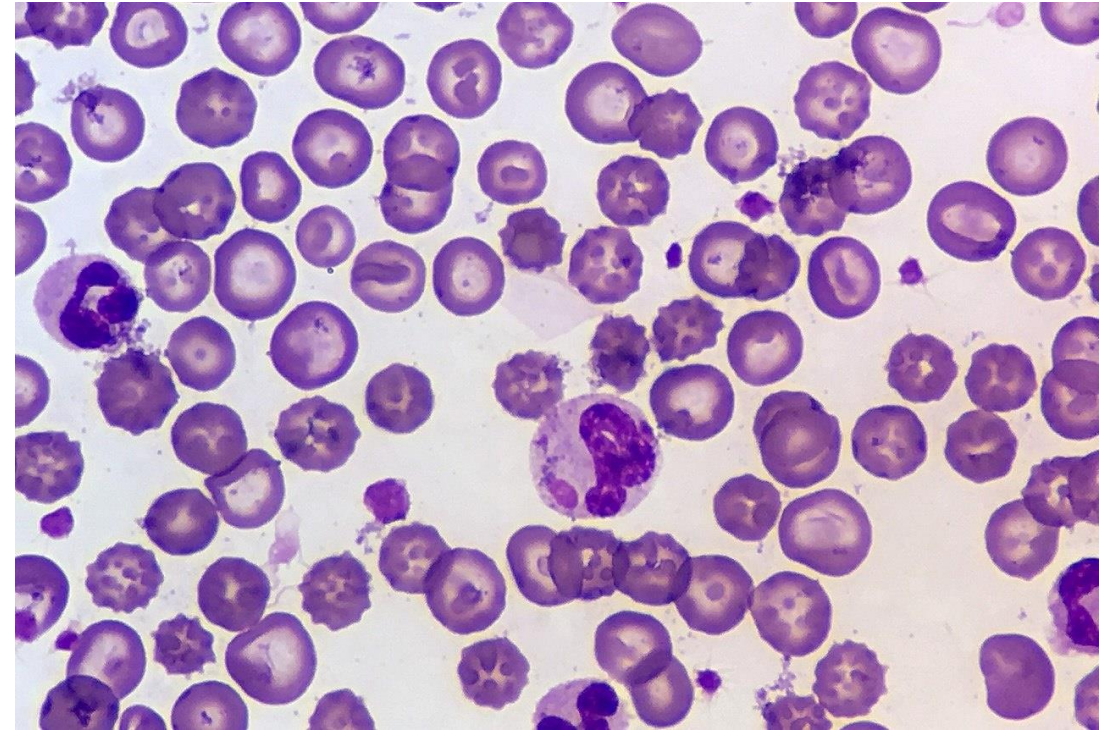

# AIM

Analyse the cascade effect of these two diseases on the Yellowstone ecosystem by simulating different scenarios of disease severity and frequency

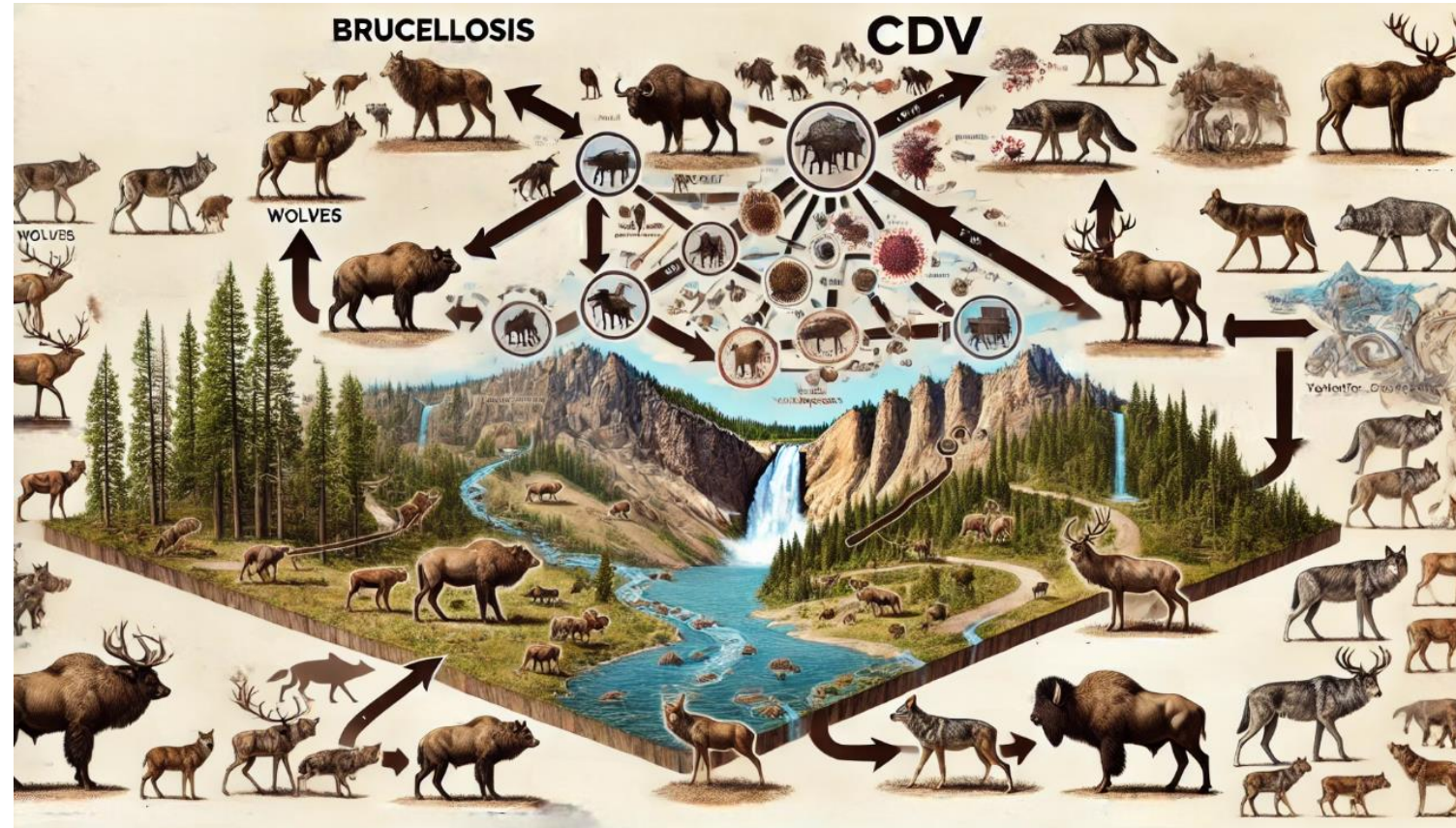

# Why Yellowstone and Kruger?



## BRUCELLOSIS



### YELLOWSTONE

- Introduced through domestic cattle 1917
- Primarily affects bison
- Calf mortality is the main symptom
- Well established: 60% infection rates of adult female bison



### KRUGER

- Present at least from 1970s
- Primarily affects African buffalo
- Calf mortality is the main symptom
- 15% infection rates in female buffalo



# Why Yellowstone and Kruger?



## Canine Distemper Virus (CDV)



### YELLOWSTONE

- Since wolf reintroduction in the 1990s.
- Primarily affects Wolves
- Notable mortality rates, particularly among pups



### KRUGER

- Several fatal epidemics in canids within the Serengeti-Mara ecosystem from 1970s
- 1994: outbreak spread in hyenas, bat-eared foxes and leopards in Maasai Mara
- potential outbreaks in Kruger as the virus is present in lions, hyenas, wild dogs, leopard



# FRAMEWORK

Disease dynamics within a framework that includes:

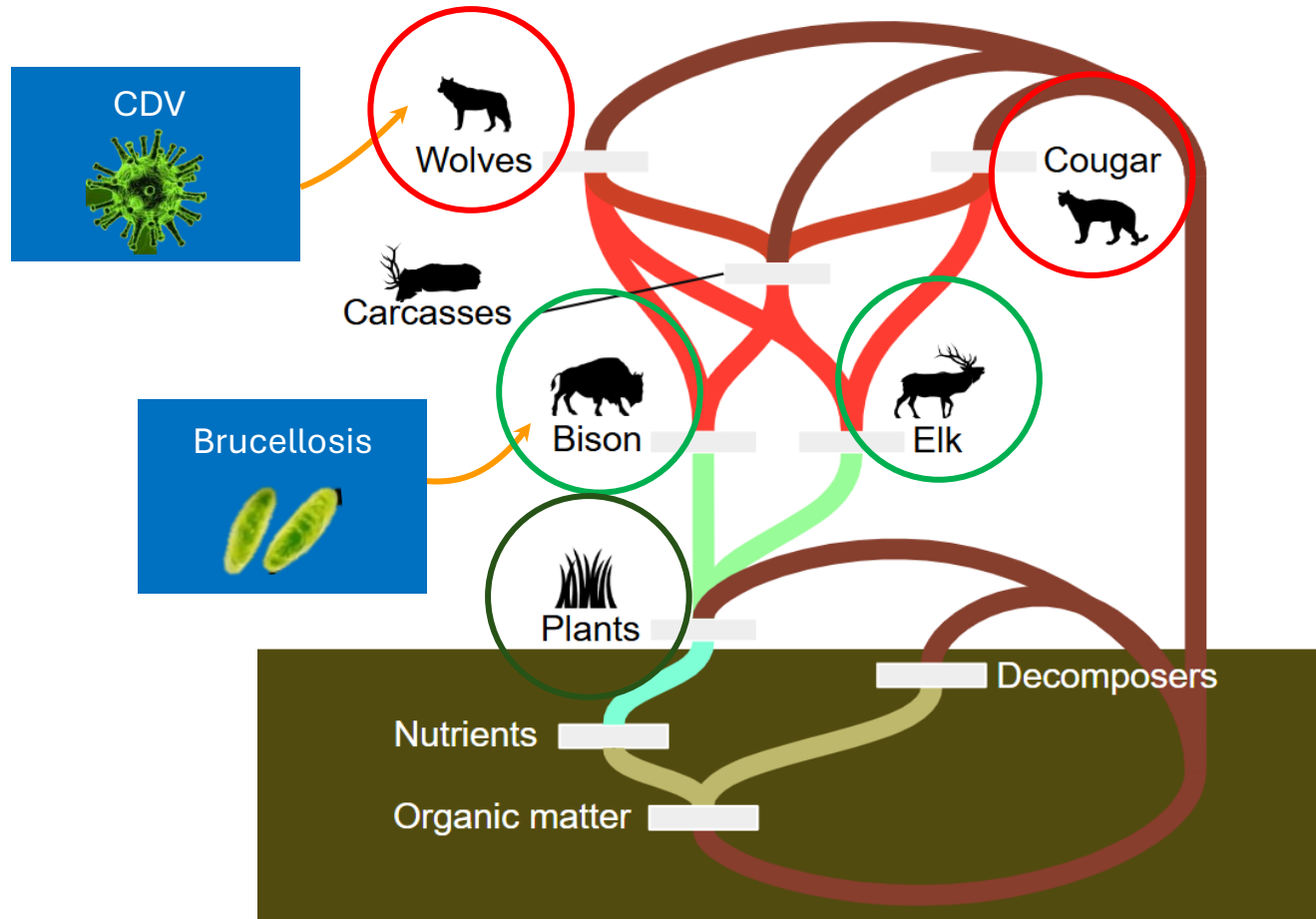

# The model is adaptable to the Kruger National Park ecosystem



# The disease model

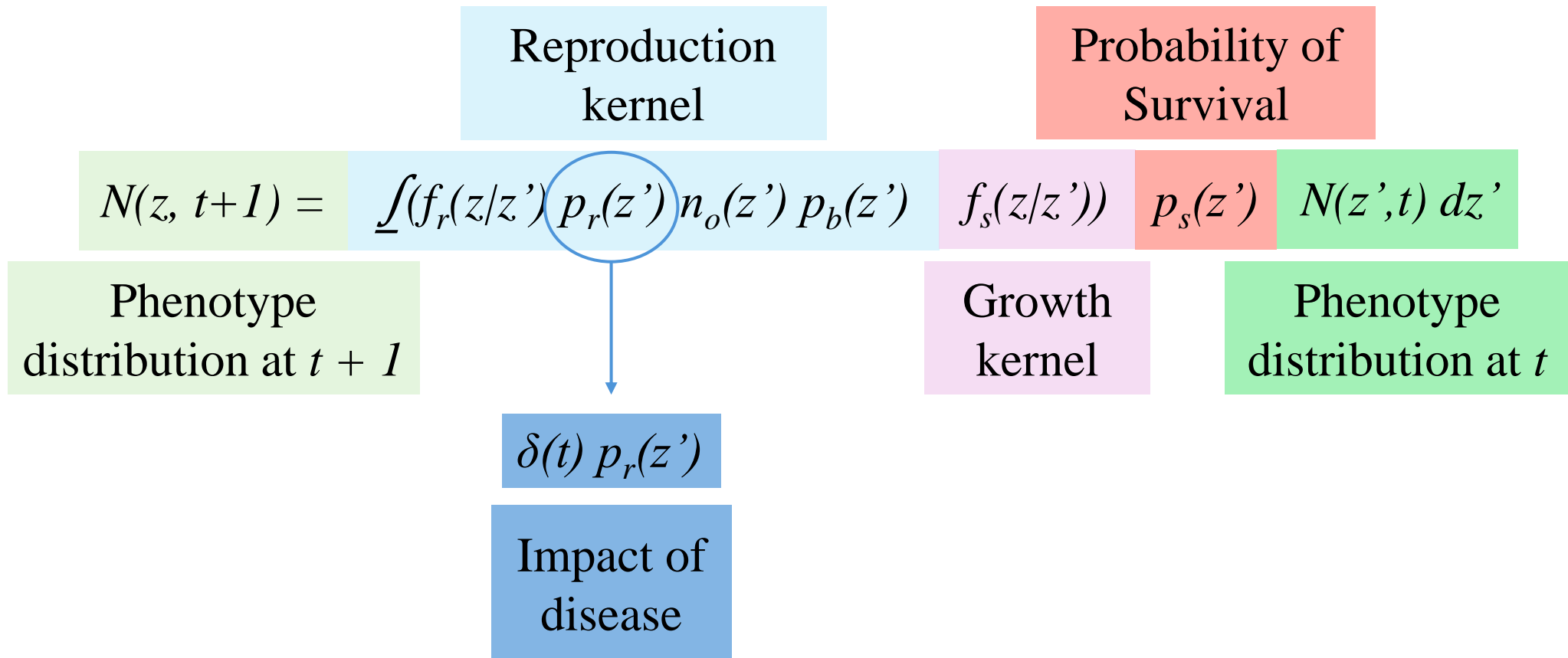



# BRUCELLOSIS

# Canine Distemper Virus (CDV)



## Frequency

## Severity (% recruitment)

$\phi = 1.0$  (chronique)

$\delta(t) = 75\%$  (low)

$\delta(t) = 50\%$  (mid)

$\delta(t) = 25\%$  (high)

## Frequency

## Severity (% recruitment)

$\phi = 1/10$  years (infrequent)

$\delta(t) = 70\%$  (low)

$\phi = 1/5$  years (mid)

$\delta(t) = 40\%$  (mid)

$\phi = 1/3$  years (frequent)

$\delta(t) = 10\%$  (high)

Low — Frequency & Severity — High

# Equilibrium

	Frequency	Severity
<b>Brucellosis</b>	<b>0</b>	<b>0</b>
<b>CDV</b>	<b>0</b>	<b>0</b>

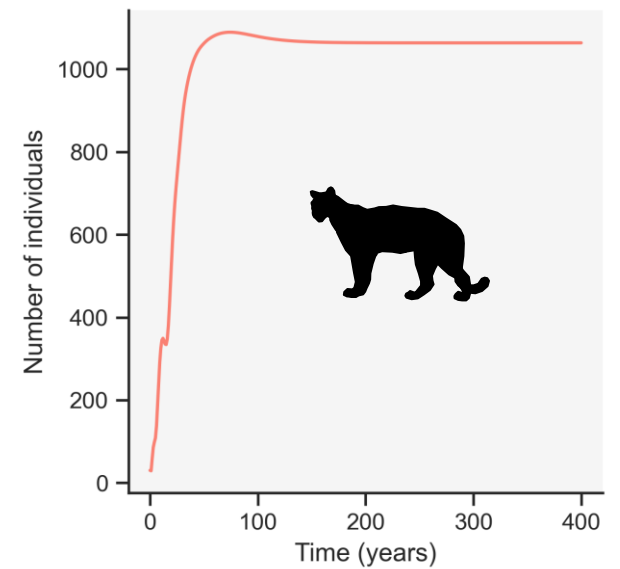
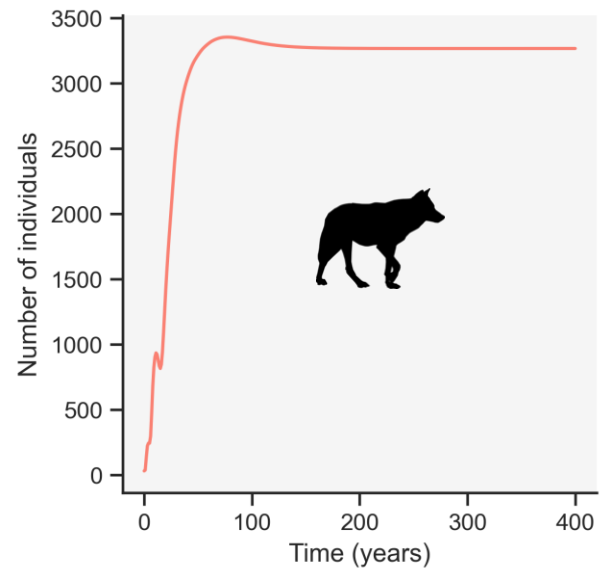
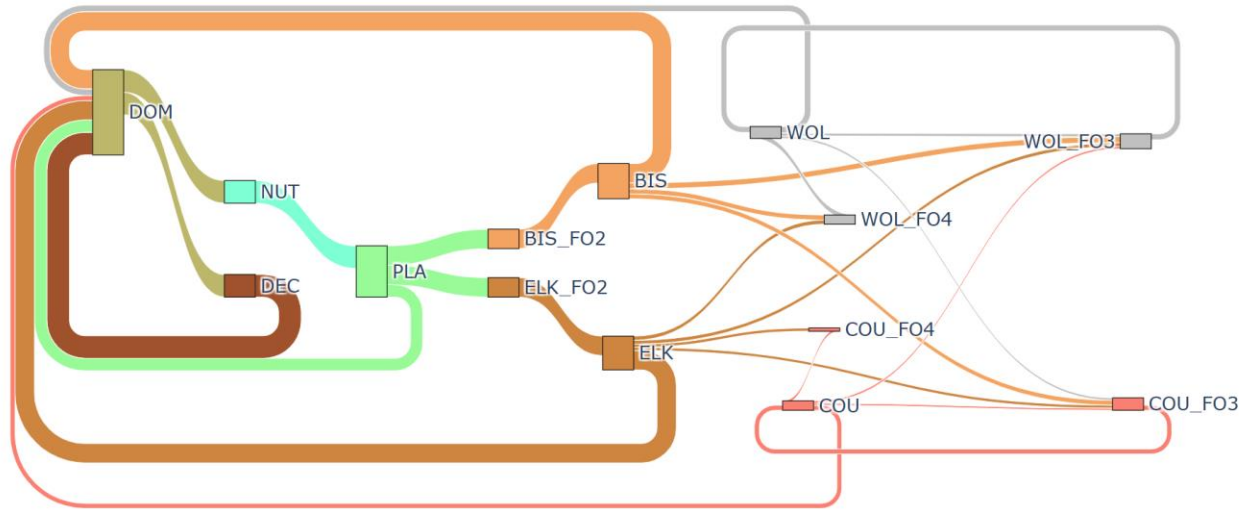
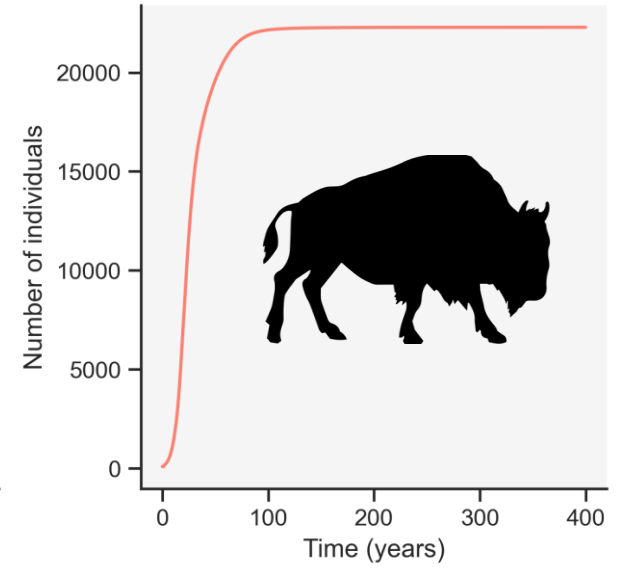
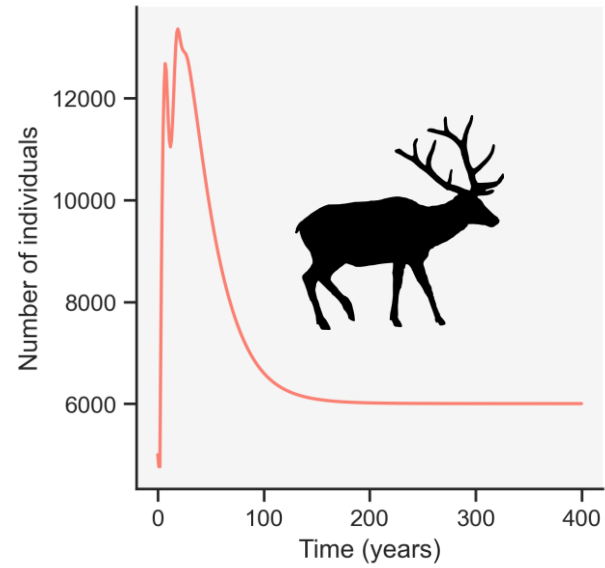

# YELLOWSTONE CONDITIONS

	Frequency	Severity
<b>Brucellosis</b>	<b>chronic</b>	<b>50%</b>
<b>CDV</b>	<b>5y</b>	<b>40%</b>

Low — Frequency & Severity — High

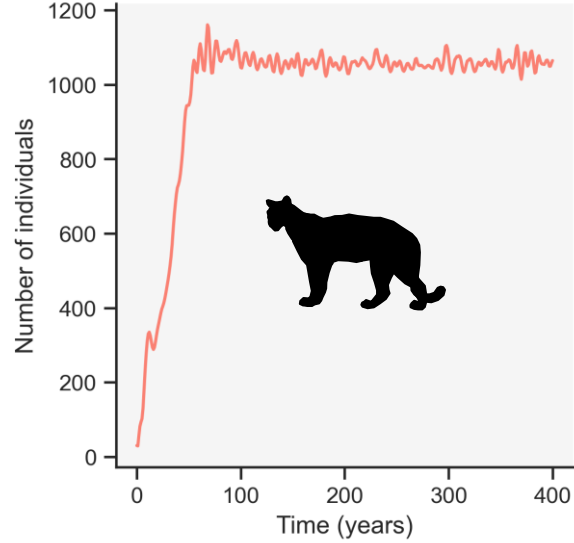
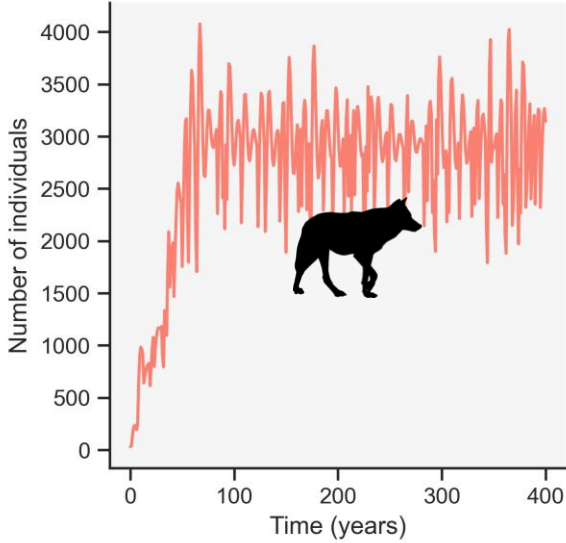
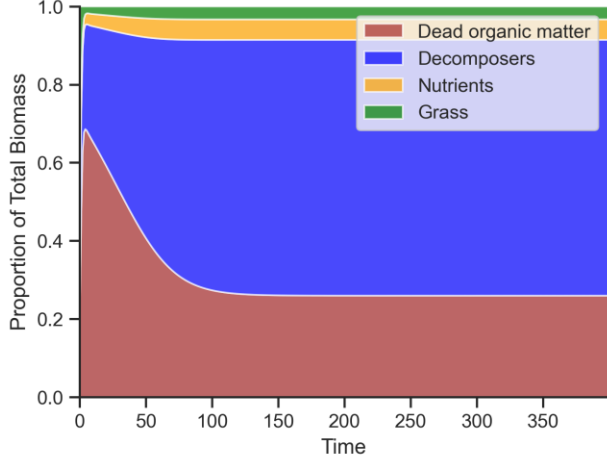
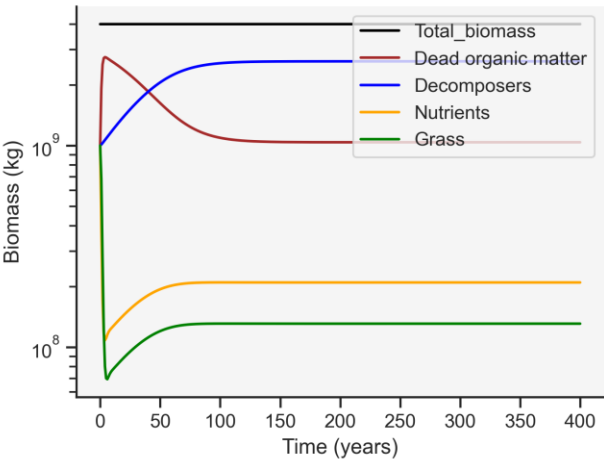
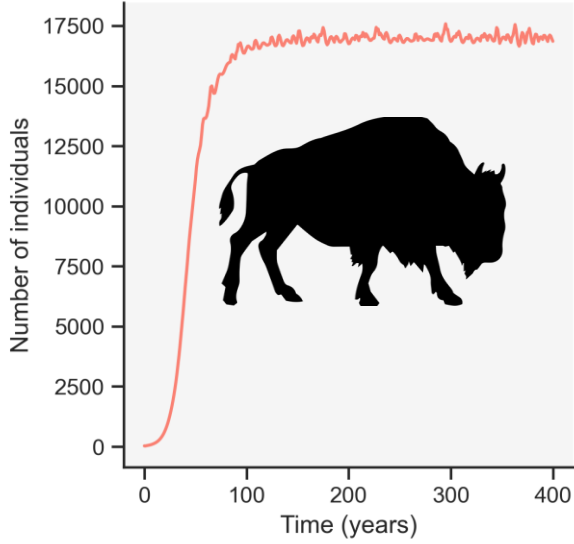
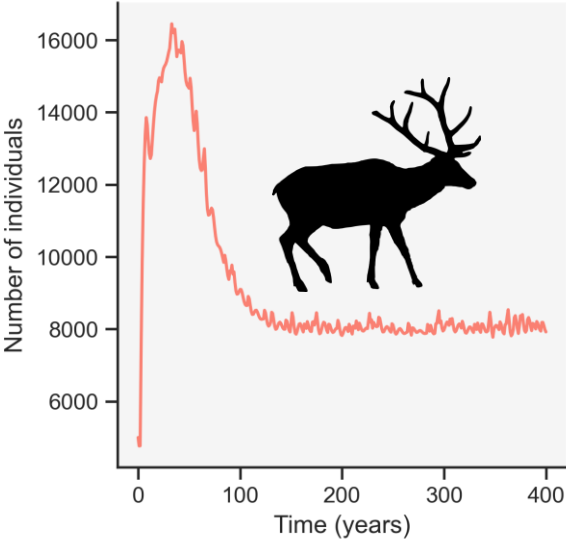

# BRUCELLOSIS

	Frequency	Severity
<b>Brucellosis</b>	chronic	<b>70%</b>
CDV	5y	40%

	Frequency	Severity
<b>Brucellosis</b>	chronic	<b>50%</b>
CDV	5y	40%

	Frequency	Severity
<b>Brucellosis</b>	chronic	<b>25%</b>
CDV	5y	40%

Low — Frequency & Severity — High

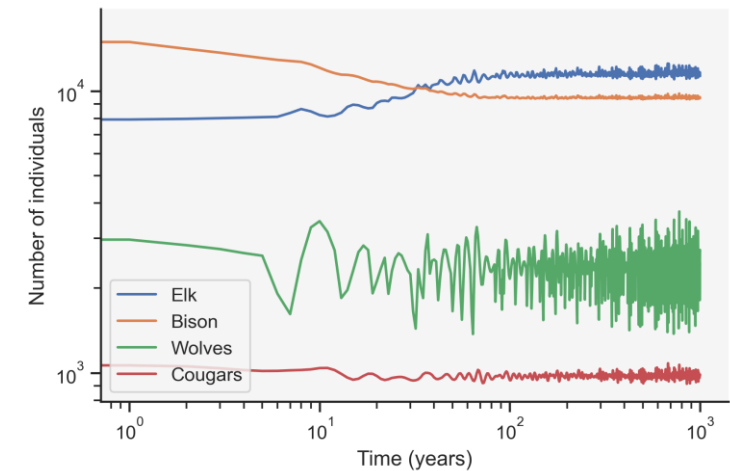
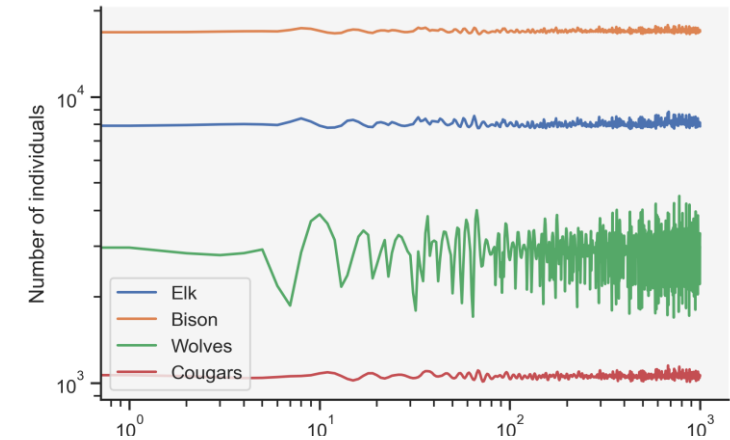
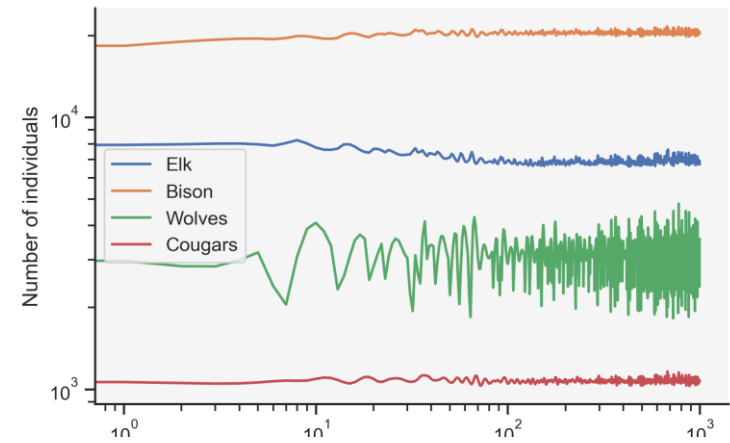

# BRUCELLOSIS

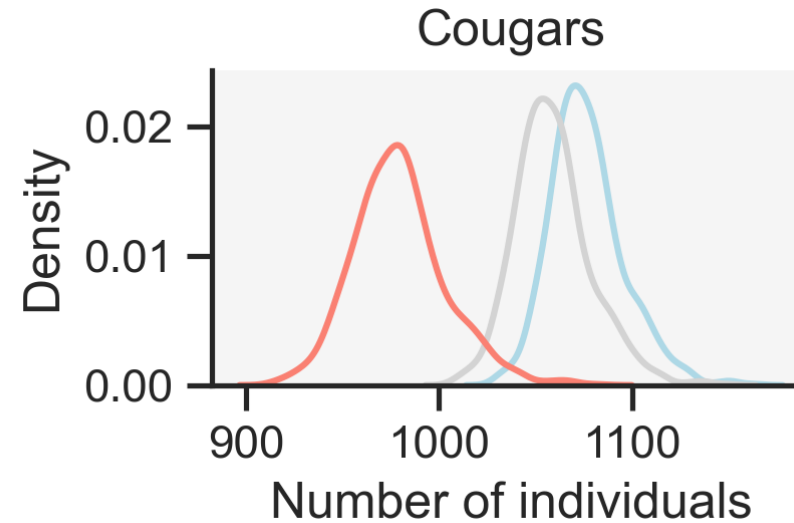
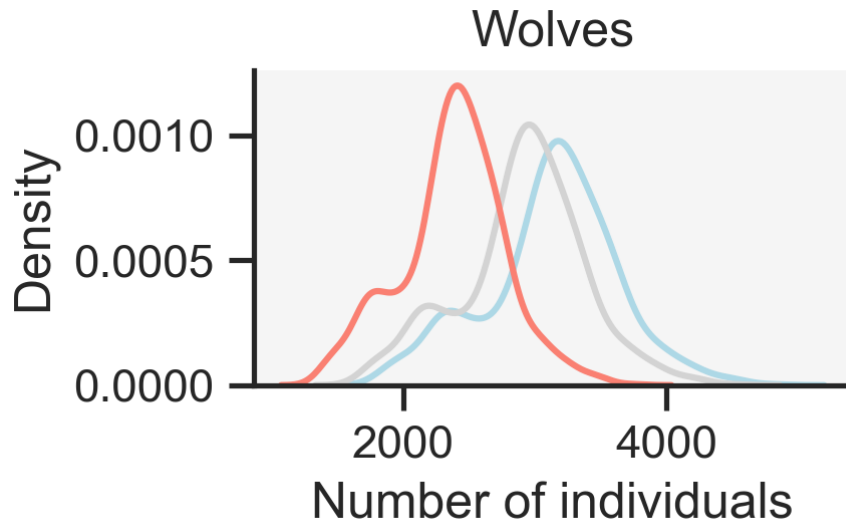
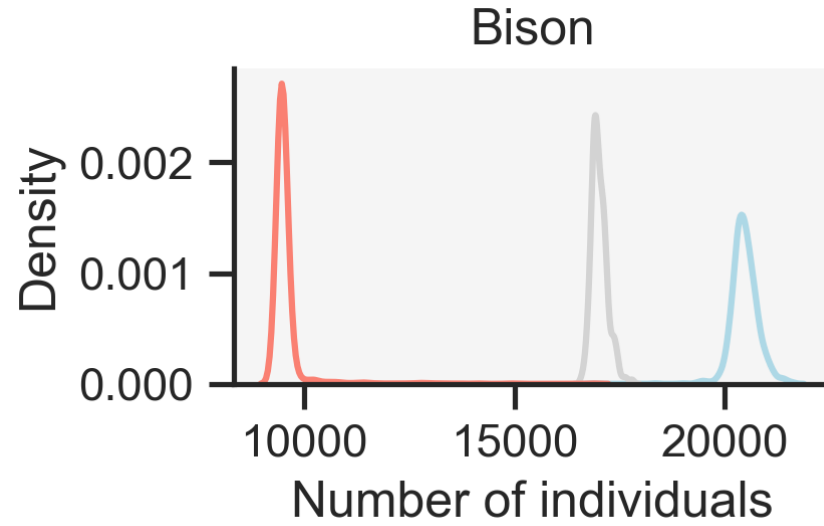
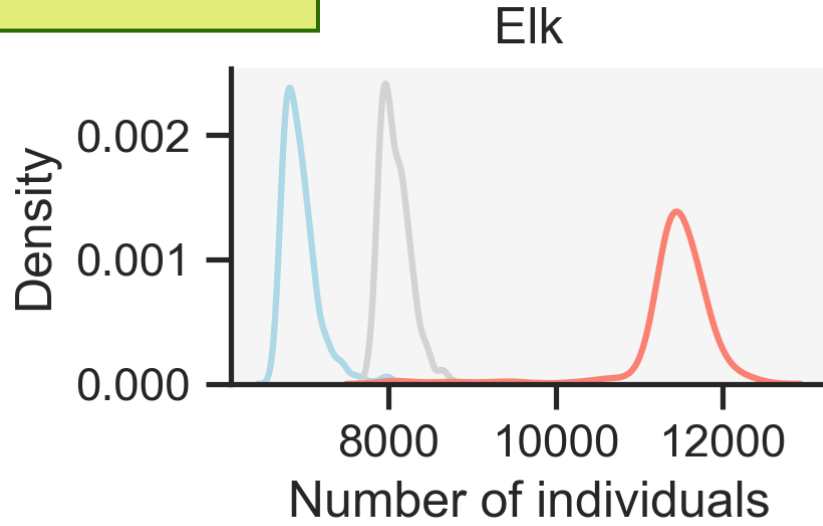

Low — Frequency & Severity — High

# CDV - Frequency

	Frequency	Severity
Brucellosis	chronic	50%
<b>CDV</b>	<b>10y</b>	40%

	Frequency	Severity
Brucellosis	chronic	50%
<b>CDV</b>	<b>5y</b>	40%

	Frequency	Severity
Brucellosis	chronic	50%
<b>CDV</b>	<b>3.5y</b>	40%

Low — Frequency & Severity — High

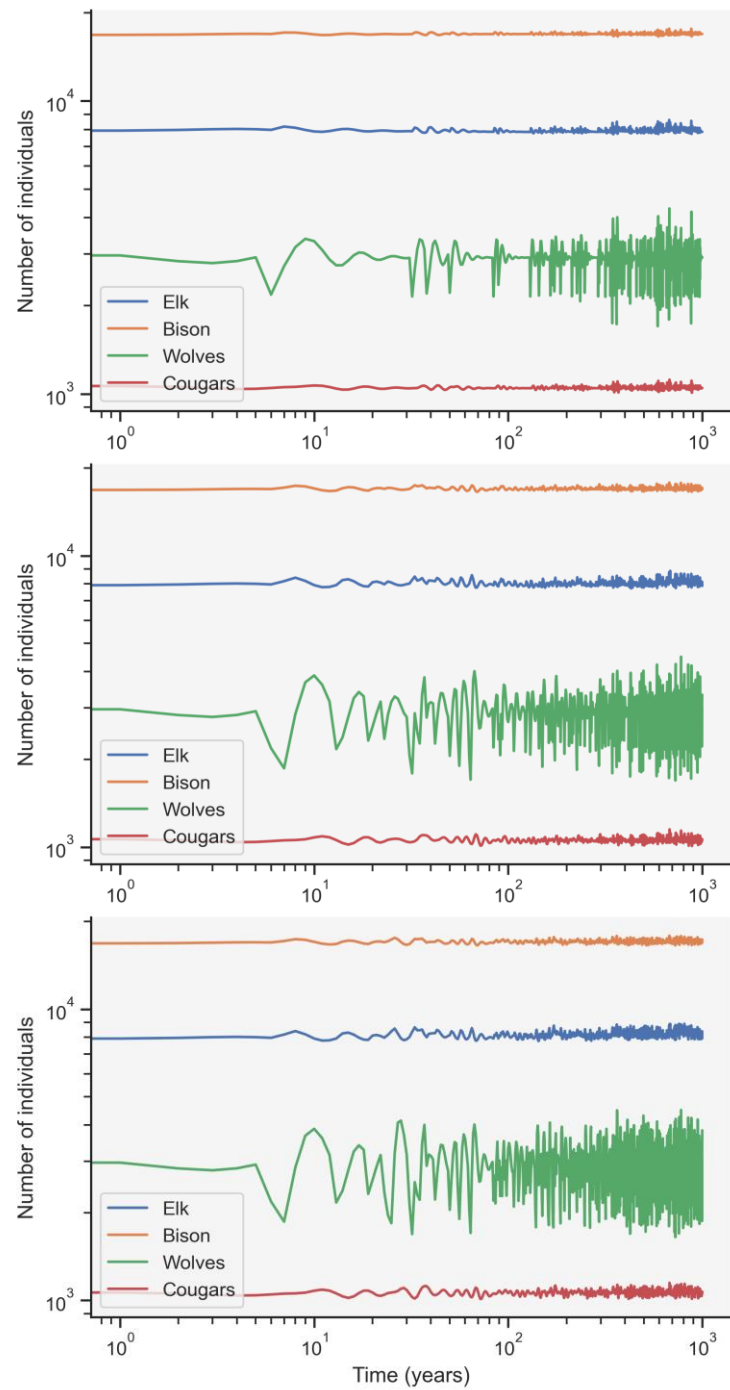

# CDV - Frequency

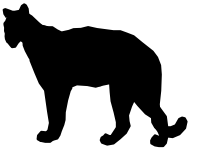
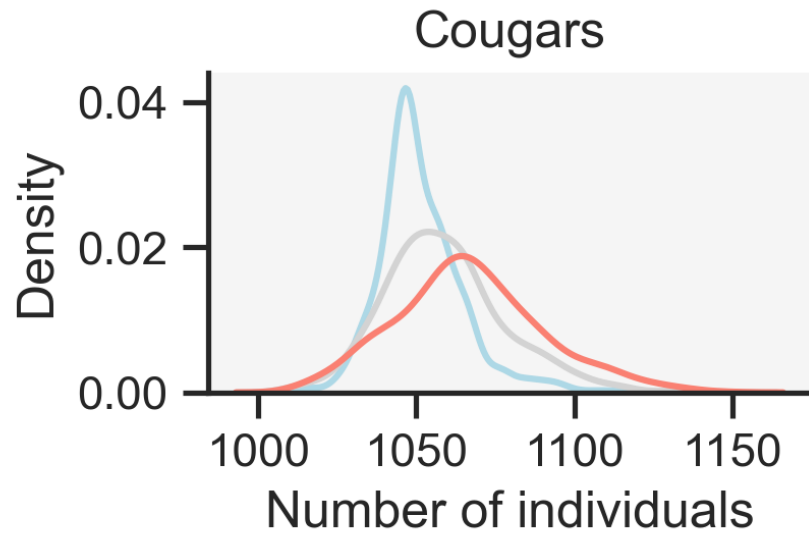
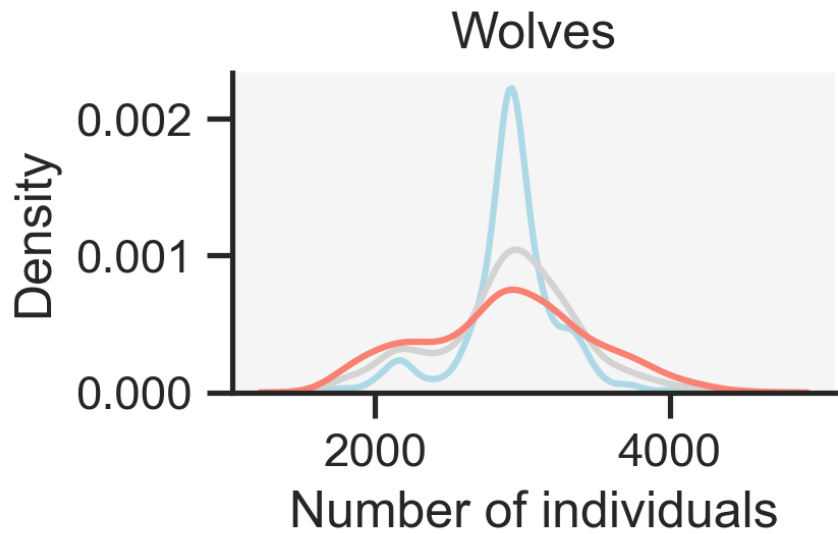
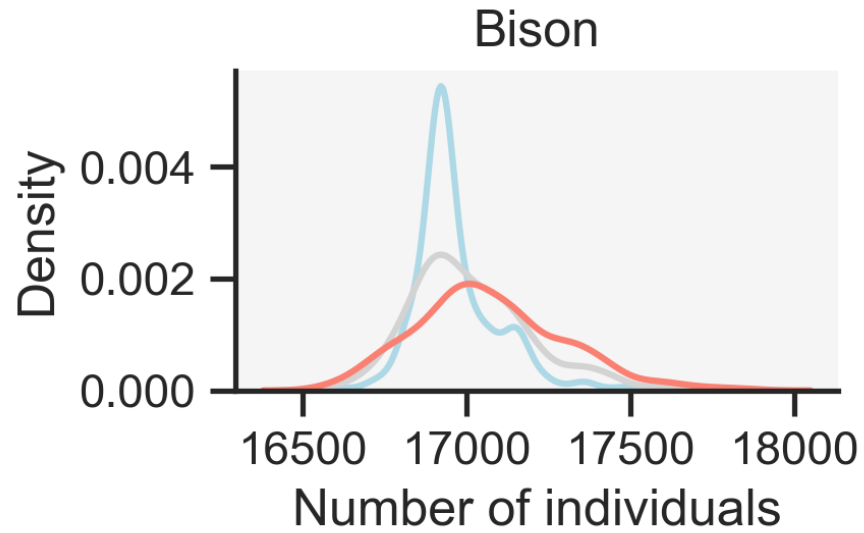
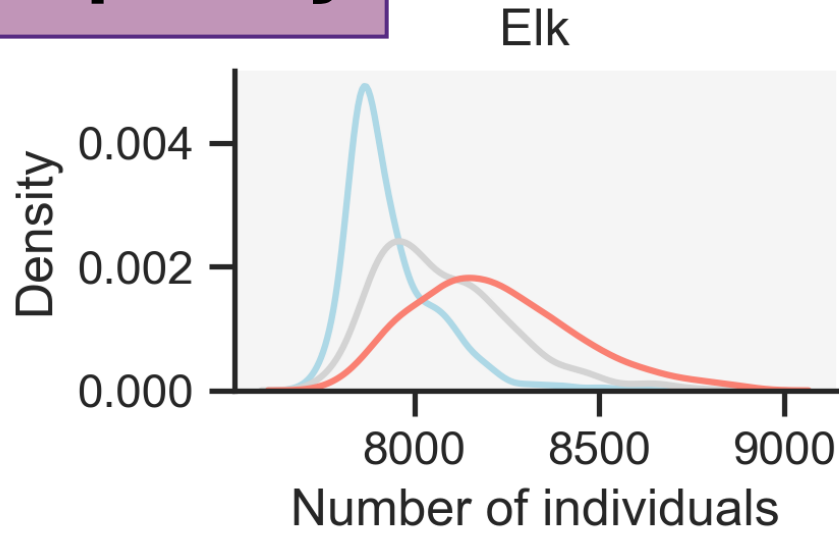

Low — Frequency & Severity — High

# CDV - Severity

	Frequency	Severity
Brucellosis	chronic	50%
<b>CDV</b>	5y	<b>70%</b>

	Frequency	Severity
Brucellosis	chronic	50%
<b>CDV</b>	5y	<b>0.4%</b>

	Frequency	Severity
Brucellosis	chronic	50%
<b>CDV</b>	5y	<b>10%</b>

Low — Frequency & Severity — High

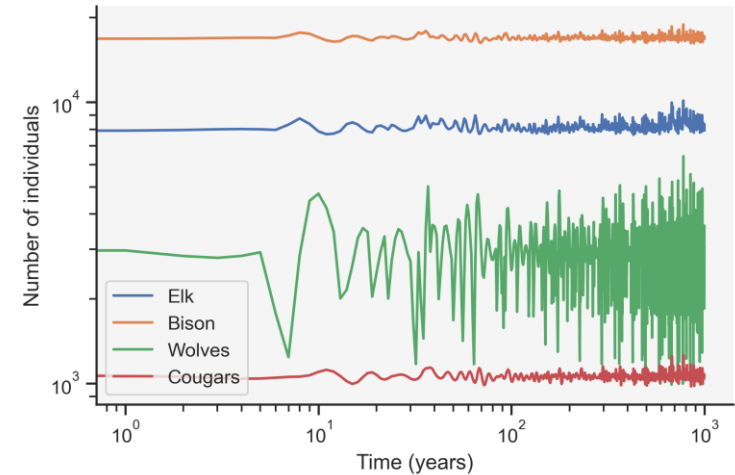
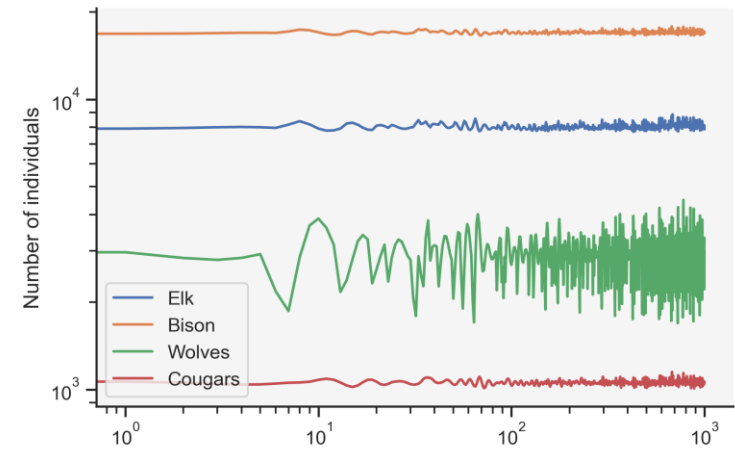
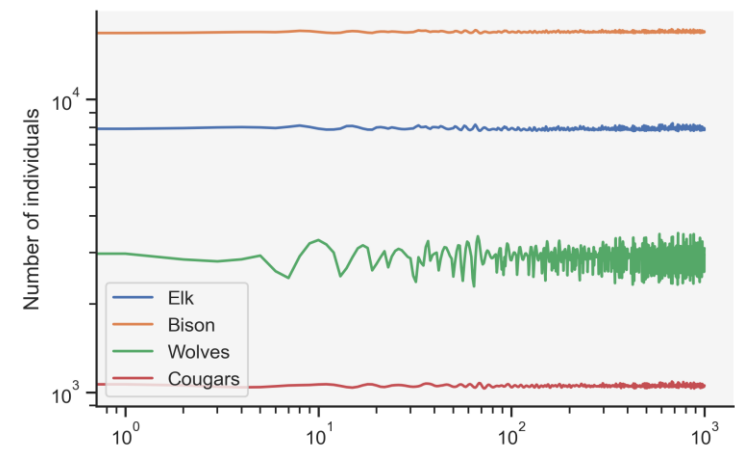

# CDV - Severity

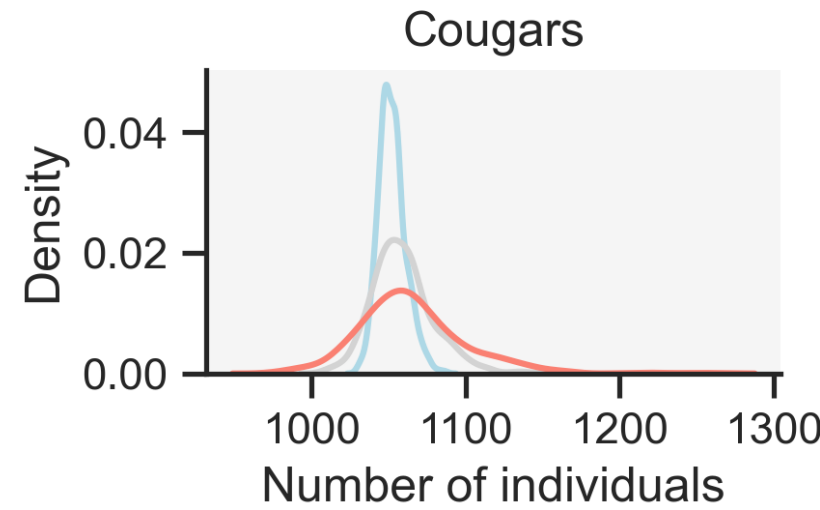
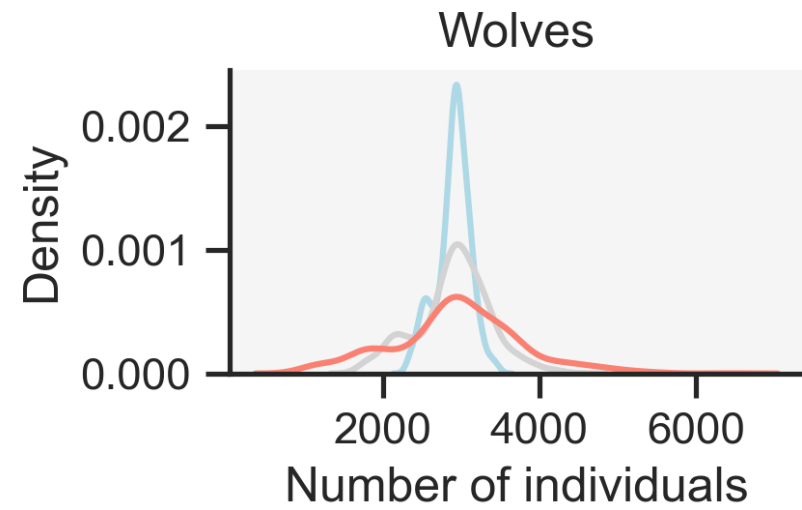
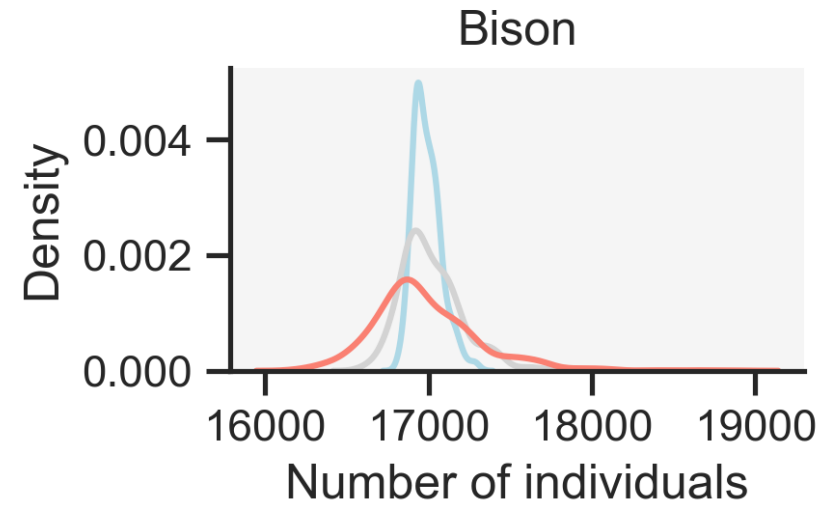
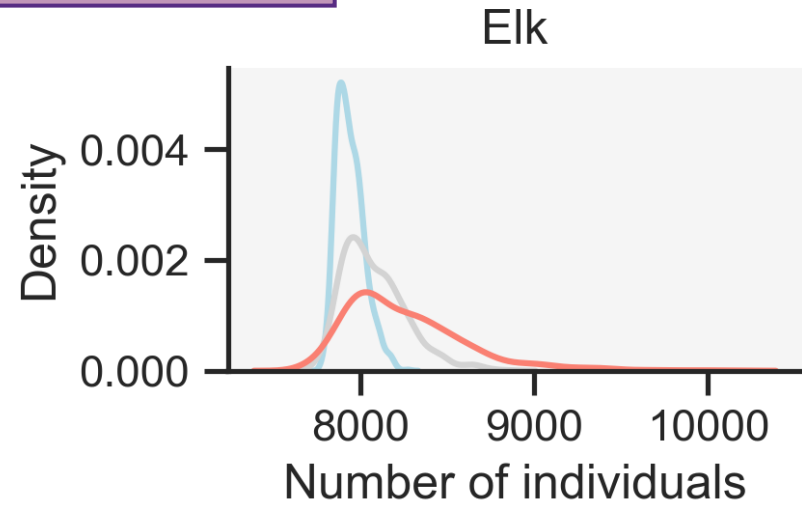

Low — Frequency & Severity — High

# CONCLUSIONS: disease cascade effect



Change the dynamics of the system

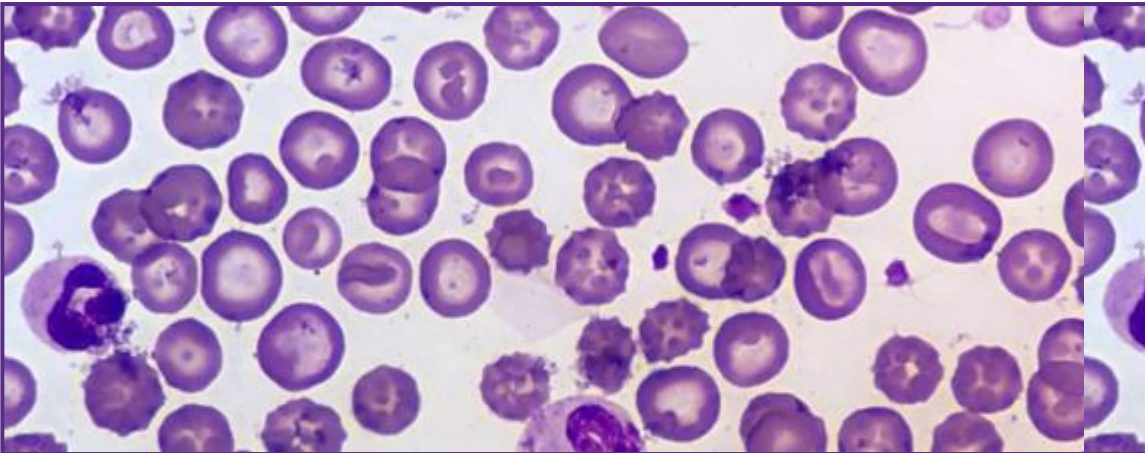

The dynamics become more variable with more fluctuations, but don't change

# Model versatility

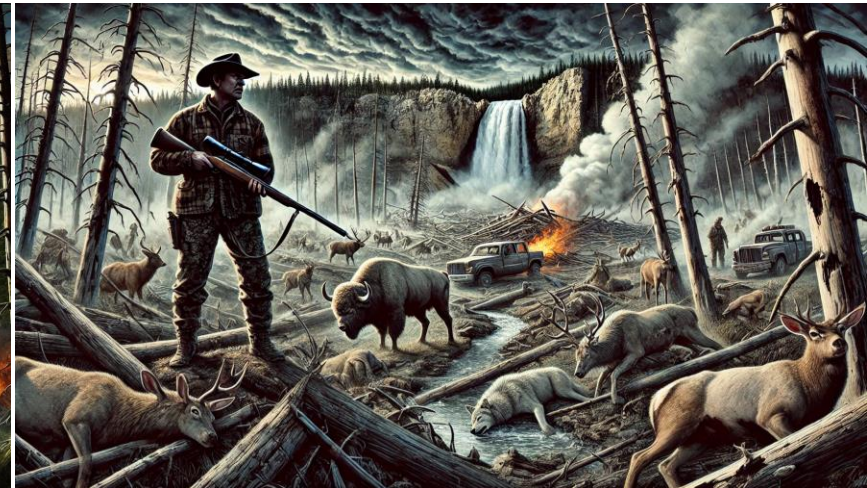



# Thank you!

[marti.muraro@biology.ox.ac.uk](mailto:marti.muraro@biology.ox.ac.uk)

